

# T 158-8P6R33.391 6x6.2

# FORESTRY



## 6x6 LOG-TRUCK WITH SEMITRAILER

Combining the outstanding features of the TATRA PHOENIX Euro 6, 6x6 chassis with a detachable front wheel drive, superstructure, telescopic semi-trailer UMIKOV NPK 39 T and the powerful EPSILON Q 170 Z loading crane, a highly efficient and versatile forwarder designed for logging operations and timber road transport is provided.

TATRA PHOENIX offers a unique combination of the TATRA chassis with a spacious cabin, modern PACCAR MX Euro 6 engines and ZF or Allison transmissions. Thanks to this, the TATRA PHOENIX trucks can take you further - to the locations inaccessible to other trucks, and to higher profits due to higher efficiency.

A three-axle telescopic semi-trailer UMIKOV NPK 39 T with sliding stanchions is made of high-quality materials of grade 700. Hydraulic frame extension by up to 3,000 mm can be continuously operated from the HNJ seat without a side lock, by locking via hydraulic locks, including the rear hydraulic feed of two cross members by 1,250 mm. Thanks to this system and low operating weight, the semi-trailer is highly versatile and highly effective.

The vehicle uses the hydraulic loading crane EPSILON Q170 Z96. The boom length up to 9.6 meters with the end capacity of 1,600 kg makes the equipment powerful and versatile.

Thanks to these parameters, the loading and unloading time can be shortened by up to 60% compared to other models, which brings improved economy of work and operational cost savings.

- HIGH PRODUCTIVITY
- EFFICIENT BOTH OFF-ROAD AND ON-ROAD
- VERSATILITY OF TELESCOPIC SEMI-TRAILER
- HIGH-PERFORMANCE LOADER
- COMFORT FOR DRIVERS

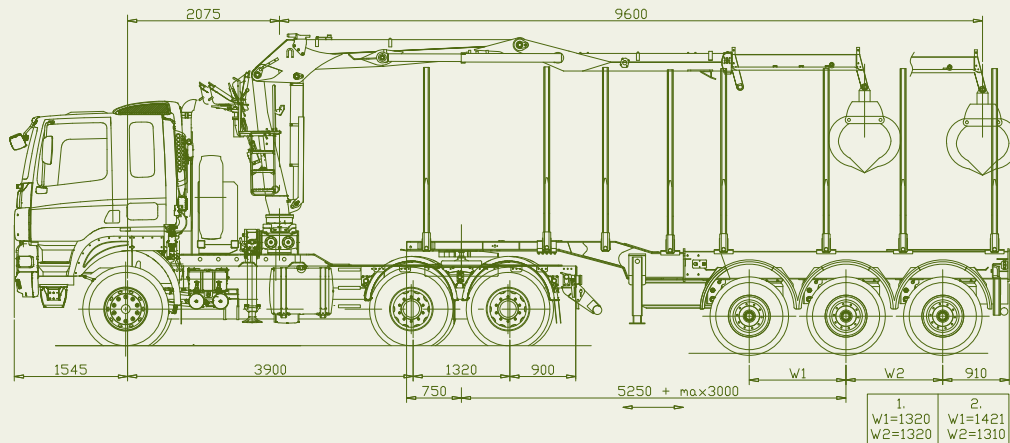

TATRA TAKES YOU FURTHER

[tatratrucks.com](http://tatratrucks.com)



# TATRA PHOENIX Euro 6

# T 158-8P6R33.391 6x6.2

## 6x6 LOG-TRUCK WITH SEMITRAILER

TATRA PHOENIX EURO6

### ENGINE

Type	PACCAR MX-13 Euro 6
No. of cylinders	6
Swept volume	12,900 cm <sup>3</sup>
Net power	340 kW/1,700 rpm
Net torque	2,300 Nm/1,000-1,450 rpm
SCR, EGR, DPF exhaust gas treatment system	
Optional:	
- MX-13 engine, cylinder capacity 12,900 cm <sup>3</sup> , power 300; 375 kW/1,450 rpm	
- Decompression MX Engine Brake as standard	

### TRANSMISSION

Manual ZF- type 16S 2530 TO with integrated retarder-intarder	
Number of speeds	
- forward	16
- reverse	2
Hydraulically operated clutch, diam. 1x430 mm.	
Optional: automated 16-speed ZF 16AS 2630 AS Tronic, or automatic Allison 4500	

### TRANSFER CASE

Two-speed TATRA 2.30 TRK, ratio 0.95/1.44.	
Optional: one-speed (gear ratios 1.12; 1.28; 1.46)	

### FRONT AXLE

Steered, driven with swinging half-axes, disengageable front drive, axle differential lock.	
Air bellows and telescopic shock absorbers.	
Optional: torsion stabilizer	

### REAR AXLES

Driven, with swinging half-axes, axle differential locks, inter-axle differential lock.	
Air suspension with bellows, combined with coil springs, telescopic shock absorbers and torsion stabilizer at the last axle (optional).	

### STEERING

Left-hand sided, monoblock.

### BRAKES

Four independent brake systems: service, emergency, parking, relief. MX engine brake  
Engine Brake

### TYRES, DISCS

	front	rear
Tyres	385/65 R22.5	315/80 R22.5
Discs	22,5x11,5	9,00x22,5

### CAB

Over-engine, sleeper, hydraulically tilting, with engine-dependent water heating, optionally with A/C or an independent heater  
Number of seats 2

### FUEL TANK

steel, 300 liters + 45-liter AdBlue

### DIMENSIONS

Width	2,550 mm
Wheelbase	
- front	1,942 mm
- rear	1,774 mm
Ground Clearance	280 mm

### WEIGHTS

Curb weight (w/o superstructure)	10,800 kg
Payload	19,200 kg
Maximum front axle load	9,000 kg
Maximum rear axle load	2x11,500 kg
Maximum trailer weight	30,000 kg
Maximum laden weight of vehicle combination	54,000 kg

### ELECTRIC EQUIPMENT

Power grid voltage	24 V
Batteries	2x12V 180 Ah
Alternator	24 V / 80 A

### FEATURES

Climbing capacity at 30,000 kg	100 %
Max. speed (with speed limiter)	85 km/h
Turning diameter (track)	18±1 m
Fording ability	800 mm

### SEMI-TRAILER - UMIKOV

Type	NPK 39T
Telescopic semi-trailer with sliding stanchions intended for the timber transport in lengths from 2 to 14 m.	
Hydraulic frame extension by 3,000 mm and rear hydraulic shift of two cross members by 1,250 mm.	
Three BPW ECO PLUS axles or SAF axles as per choice, of which two are lifting. Drum or disc brakes as per client's choice. Air suspension.	
Curb weight of the semi-trailer depending on the cross member design from 6,350 kg	
Wheelbase options	W1. 1,320 mm/1,320 mm, W2. 1,421/1,310 mm
Maximum axle load	3x9,000 kg
Maximum semi-trailer weight	42,000 kg

### HYDRAULIC CRANE - EPSILON

Type	Q170 Z 96
Lifting class, group	H1 B4
Net lifting torque	158 kNm
Total boom reach	9,600 mm
Pump	PARKER F 2 - 53/53 R
Grapple type	EPSILON FG 53
Weight of crane including props	2,720 kg
Capacity at the end	3,950 kg / 4 m 3,150 kg / 5 m 2,600 kg / 6 m 2,210 kg / 7 m 1,910 kg / 8 m 1,670 kg / 9 m

tatratrucks.com



### TATRA TRUCKS a.s.

Areál Tatry 1450/1, 742 21 Kopřivnice, Czech Republic  
tel.: +420 556 494 332, fax: +420 556 494 304, e-mail: ou@tatra.cz