

# T 158-8P6R44.261 8x8.2

# COMMERCIAL

## 8x8 ONE-WAY TIPPER

The TATRA PHOENIX Euro6 combines the unique TATRA chassis with a spacious and comfortable cab, modern PACCAR MX Euro 6 engines and ZF transmissions. With this combination TATRA can take you further - to the locations inaccessible to other trucks. Moreover, thanks to very efficient operation and productivity with the TATRA PHOENIX model you will even achieve higher profits.

The outstanding productivity of this truck results from high payload and high off-road transport speed. With TATRA trucks you can therefore carry more freight faster.

Powerful PACCAR MX Euro 6 engines offer reasonable operating costs, even in difficult terrain. On paved roads or highways you can disconnect the front wheel drive to achieve better operating results. Compared to competing vehicles with rigid axles, TATRA PHOENIX achieves higher speeds and favourable fuel consumption. TATRA PHOENIX is also more comfortable thanks to a unique combination of the TATRA chassis concept with the air suspension on all axles.

TATRA PHOENIX vehicles use ZF transmissions, both manual and automated, or fully automatic Allison transmissions. The automated 16-speed AS Tronic version offers the driver perfect driving comfort, both in "standard auto" shift mode, or "offroad auto" mode, or in the manual mode. In addition, AS Tronic transmissions reduce fuel consumption through shifting at the optimum speed, and protect the drive train from driver error, such as overspeeding or burning the clutch. The automated AS Tronic transmission is also equipped with a handy "Hill Holder" system. The vehicle is equipped with the powerful MX Engine Brake as standard.

A VS-Mont's body, model VSPN/S1G, features the capacity of 18 m<sup>3</sup> and is made of high-strength HARDOX steel, featuring also a hydraulically operated tailgate and conical shape for faster dumping. The vibration plate inbuilt into the body bottom also helps fast emptying.

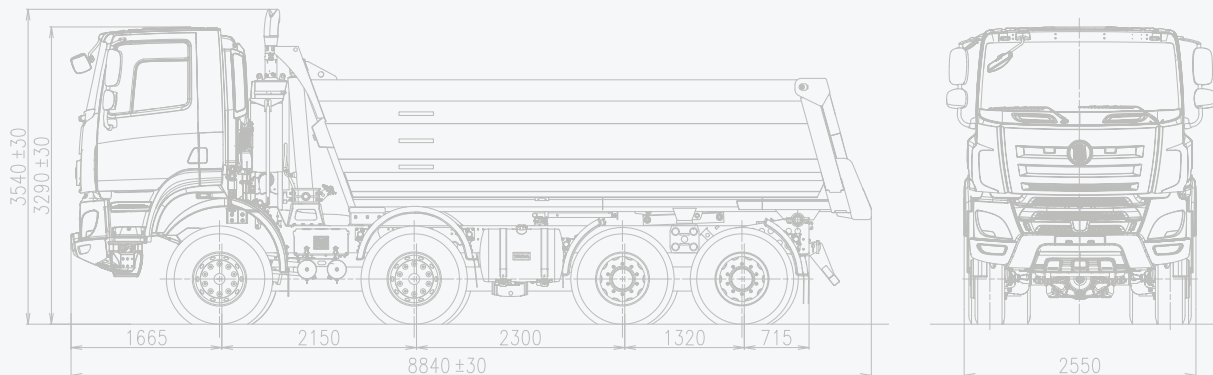

TATRA TAKES YOU FURTHER

[tatratrucks.com](http://tatratrucks.com)

# TATRA PHOENIX Euro 6



# T 158-8P6R44.261 8×8.2

## 8×8 ONE-WAY TIPPER

### ENGINE

Type	PACCAR MX340 Euro 6
No. of cylinders	6
Swept volume	12,900 cm <sup>3</sup>
Net power	340 kW/1,450 rpm
Net torque	2,300 Nm/1,000-1,400 rpm
SCR, EGR, DPF exhaust gas treatment system	
The decompression MX Engine Brake as standard	
Optional:	
- MX-11 engine, cylinder capacity 10,800 cm <sup>3</sup> , power 271, 291 kW/1,700 rpm	
- MX-13 engine, cylinder capacity 12,900 cm <sup>3</sup> , power 300, 375 kW/1,450 rpm	

### TRANSMISSION

Manual, ZF type 16S2530 Ecosplit	
Number of speeds	16
- forward	16
- reverse	2
Hydraulically operated clutch, diam. 1x430 mm.	
Optional: intarder, automated Astronic transmission	

### TRANSFER CASE

Two-speed TATRA 2.30 TR shiftable at standstill (ratios of 0.94 / 1.44)  
Optional: one-speed TATRA 1.30 TR, ratios of 1.12/1.28/1.46

### FRONT AXLE

Steered, driven with swinging half-axles, disengageable front drive, axle differential lock.  
Air bellows and telescopic shock absorbers.  
Optional: torsion stabilizer  
Optional: 8×6 drive (driven 1<sup>st</sup> or 2<sup>nd</sup> axle)

### REAR AXLES

Driven, with swinging half-axles, axle differential locks, inter-axle differential lock. Heavy combined TATRA suspension - air bellows with leaf springs.

### STEERING

Left-hand sided, monoblock steering

### BRAKES

Four independent brake systems: service, emergency, parking, relief.

### TYRES, DISCS

	front	rear
Tyres	385/65 R22.5	315/80 R22.5
Discs	22.5×11.5	9.00×22.5

### CAB

Over-engine, hydraulically folding, with engine-dependent water heating. Number of seats: 2  
Optional: with A/C or independent heater, sleeper cab.

### DIMENSIONS

Wheelbases	2,150 mm + 2,560 mm + 1,320 mm
Width	2,550 mm
Wheelbase	
- front	2,074 mm
- rear	1,780 mm
Length	8,550 mm
Height	3,600 mm
Tipper body volume	18 m <sup>3</sup>

### FUEL TANK

Steel, 300 to 340 liters + 45-liter AdBlue.

### WEIGHTS

Curb weight (w/o superstructure)	13,580 kg
Payload	30,420 kg
Total weight	44,000 kg
Maximum front axle load	2×9,000 kg
Maximum rear axle load	2×13,000 kg

### ELECTRIC EQUIPMENT

Rated voltage	24 V
Batteries	2×12V, 180 Ah
Optional:	2×12V, 225 Ah
Alternator	24 V / 80 A
Preparation for the FMS connector	

### FEATURES

Climbing ability at the total vehicle weight of 44 tons	100 %
Max. speed (with speed limiter)	88 km/h
Turning radius (contour)	23.0±1.0 m

### WINTER PACKAGE

Optional: cold start equipment down to -40 °C, fuel filter preheating with water separator, heated body

TATRA PHOENIX EURO6

tatratrucks.com



TATRA TRUCKS a.s.

Areál Tatry 1450/1, 742 21 Kopřivnice, Czech Republic  
tel.: +420 556 494 332, fax: +420 556 494 304, e-mail: ou@tatra.cz